

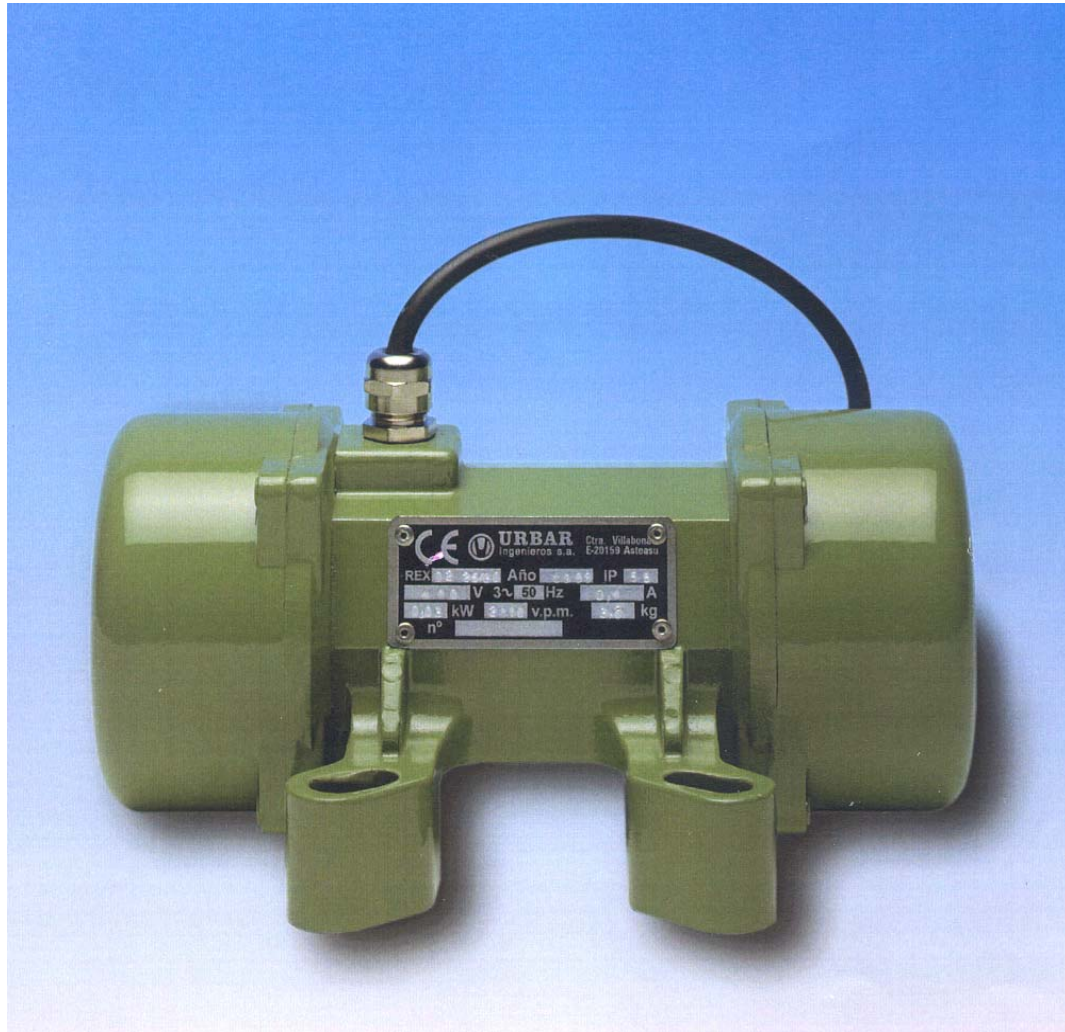

URBAR
ingenieros s.a.

Electric external vibrator for hoppers

REX-N



- Especially designed to be installed in hoppers and silos for mortar.
- Fixing device allows installation in different positions.
- Low energy consumption.
- Minimum maintenance.
- Made following the CE directives.

Electric vibrator for hoppers. REX-N.

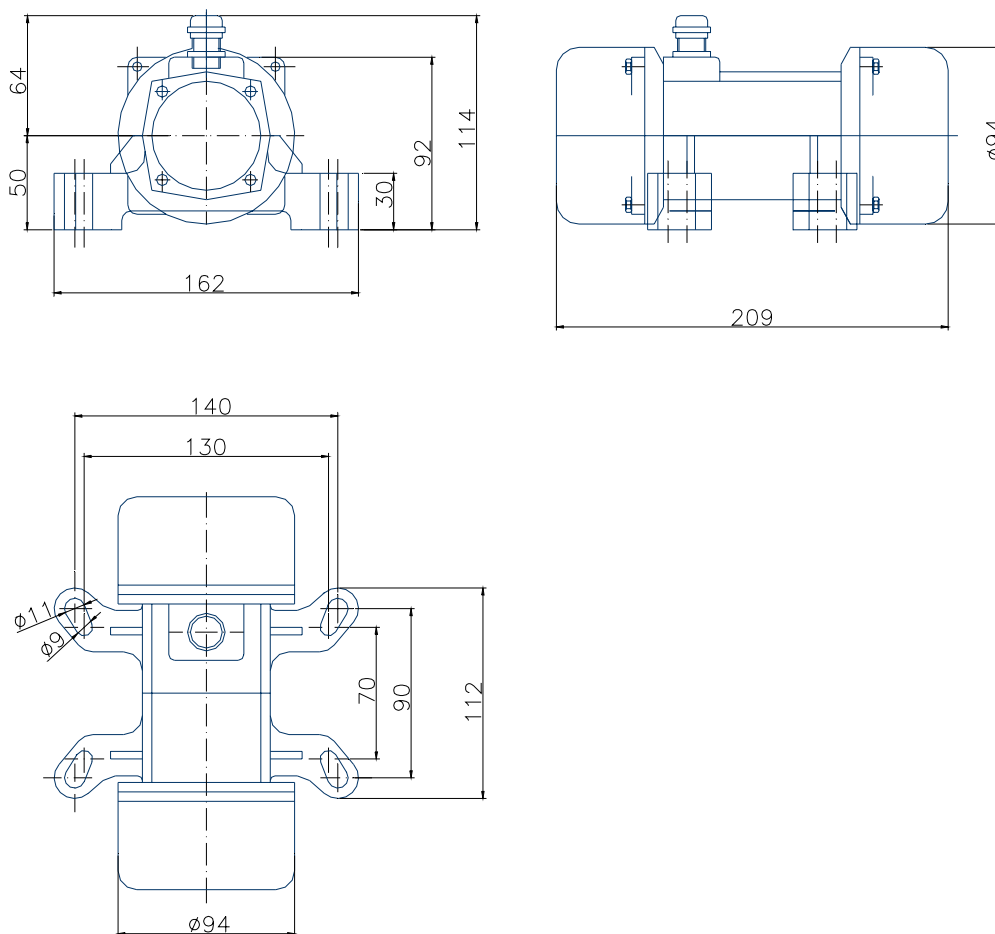

Technical characteristics

Type	Voltage	Power	Consumption	Frequency	Protection	Force	Speed	Weight
REX-N	220 V	123 W	0,59 A	50 Hz	IP-55	2,4 kN	3000 rpm	3,6 kg
	380 V		0,34 A					

Description

The REX-N vibrator is the right answer to the problem shown when the small hoppers are blocked and to the increasing use of silos for mortar.

Its simply design allows the necessary centrifugal force for the product contained in the hopper flow easily.

The fixing device is especially made for the vibrator to be installed in different positions.

Two models are available, one to be connected at 220V and the other one at 380V, both at 50Hz.



URBAR
ingenieros s.a.

Ctra. Villabona-Asteasu, km 3
Apartado 247
Tel. (+34) 943 691 500
Fax (+34) 943 692 667
E-20159 **Asteasu**

www.urbar.com
E-mail: urbar@urbar.com