



URBAR
ingenieros s.a.

Pneumatic roller vibrators

R serie



- For emptying hoppers, agitation of small particles, moving of fine powders, compactation of plastic and concrete moulds...
- For easy mounting two horizontal and two vertical holes.
- Very high centrifugal forces.
- An air silencer incorporated.

Pneumatic roller vibrators. R serie.

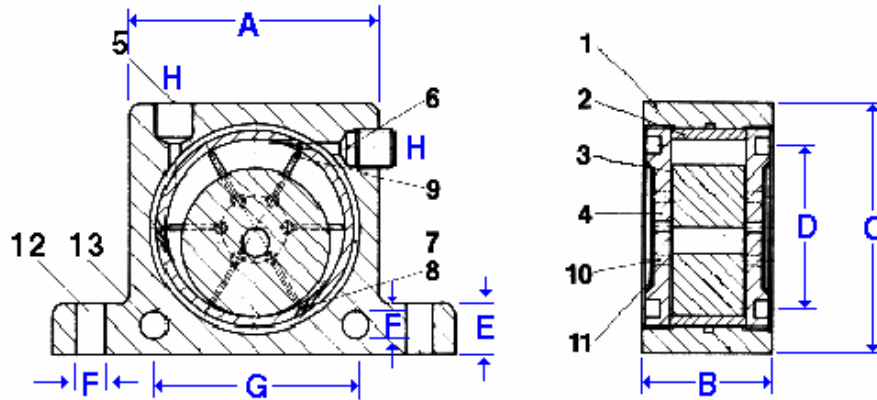

Description

- | | |
|----------------------------------|-----------------------------|
| 1 - Extruded aluminum alloy body | 7 - Air groove |
| 2 - Cast iron liner | 8 - Inlet jets |
| 3 - Steel alloy roller | 9 - Exhaust ports |
| 4 - Plastic end plates | 10 - Exhaust diffuser |
| 5 - Vertical air inlet | 11 - Silencer plate |
| 6 - Horizontal air inlet | 12 - Base mounting holes |
| | 13 - Lateral mounting holes |

Dimensions (mm) and weights (kg)

Type	A	B	C	D	E	F	G	H	Peso
R - 50	50	29	86	68	12	7	40	1/8"	0.240
R - 65	65	37	113	90	16	9	50	1/4"	0.545
R - 80	80	43	128	104	16	9	60	1/4"	0.950
R -100	100	52	160	130	20	11	80	3/8"	1.810
R -120	120	77	194	152	24	17	-	3/8"	4.260

Technical characteristics

Type	Frequency vpm x 1000			Force Newton			Air consumption l / min.		
	2 bar	4 bar	6 bar	2 bar	4 bar	6 bar	2 bar	4 bar	6 bar
R - 50	25.0	35.0	36.0	1070	2920	4220	100	145	195
R - 65	19.0	21.0	26.0	2730	4830	6120	200	300	400
R - 80	15.5	18.5	19.0	3000	6090	7450	290	430	570
R -100	11.0	14.0	16.0	3750	6750	8900	370	550	730
R -120	10.0	11.5	12.5	8000	10000	12500	500	730	970

Data obtained with a Kistler 3-axis dynamometer on a heavy laboratory test block and displayed by Kistler control monitor (COMO). Frequency and force will decrease on a less rigid mount. Specifications subject to change without notice or obligation.

Maximum temperature 140 °C = 280 °F

Noise level range 75 to 100 dBA



URBAR
ingenieros s.a.

Ctra. Villabona-Asteasu, km 3
Apartado 247
Tel. (+34) 943 691 500
Fax (+34) 943 692 667
E-20159 **Asteasu**

<http://www.adege.es/urbar>
E-mail: urbar@urbar.com