

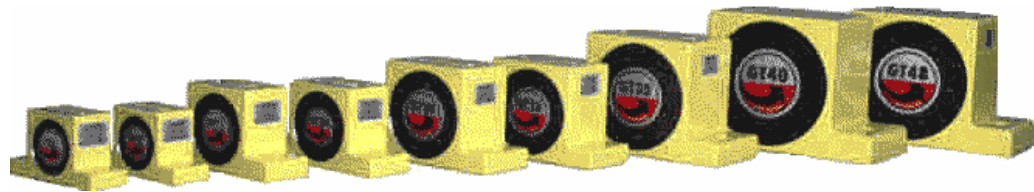

URBAR
ingenieros s.a.

**Pneumatic
golden
turbine vibrators**

GT serie



- Powerful vibration, combined with low speed range and large working moment.
- Chemically resistant, suitable for use in the food and pharmaceutical industries.
- No lubrication, only clean air is required.
- Extremely silent, between 60 and 70 dBA.

Pneumatic turbine vibrators. GT serie.

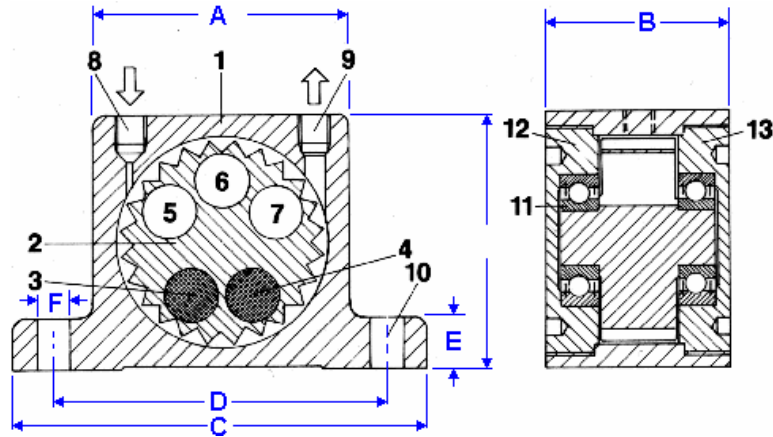

Description

- | | |
|--|--|
| 1 - Extruded aluminum alloy body | 10 - Base mounting holes |
| 2 - Aluminum turbine wheel, hard coated | 11 - Special pre-lubricated shielded bearings |
| 3-4 - High density mass for positive moment | 12 - Hard coated aluminum end plate with left-handed thread |
| 5-7 - Cavities for negative moment | 13 - Hard coated aluminum end plate with right-handed thread |
| 8 - Air inlet (BSP thread, will accept NPT) | |
| 9- Air exhaust (BSP thread, will accept NPT) | |

Dimensions and weights

Type	A	B	C	D	E	F	G	H	kg
GT-4	40.0	28.0	70.0	56.0	10.5	6.0	G 1/8"	G 1/8"	0.165
GT-6	40.0	28.0	70.0	56.0	10.5	6.0	G 1/8"	G 1/8"	0.140
GT-8	50.0	33.0	86.0	68.0	12.0	7.0	G 1/8"	G 1/8"	0.250
GT-10	50.0	33.0	86.0	68.0	12.0	7.0	G 1/8"	G 1/8"	0.255
GT-10-S	50.0	33.0	86.0	68.0	12.0	7.0	G 1/8"	G 1/8"	0.263
GT-13	65.0	42.0	113.0	90.0	16.0	9.0	G 1/4"	G 1/4"	0.565
GT-16	65.0	42.0	113.0	90.0	16.0	9.0	G 1/4"	G 1/4"	0.580
GT-16-S	65.0	42.0	113.0	90.0	16.0	9.0	G 1/4"	G 1/4"	0.614
GT-20	80.0	56.0	128.0	104.0	16.0	9.0	G 1/4"	G 1/4"	1.090
GT-25	80.0	56.0	128.0	104.0	16.0	9.0	G 1/4"	G 1/4"	1.120
GT-25-S	80.0	56.0	128.0	104.0	16.0	9.0	G 1/4"	G 1/4"	1.200
GT-30	100.0	73.0	160.0	130.0	20.0	11.0	G 3/8"	G 3/8"	2.200
GT-36	100.0	73.0	160.0	130.0	20.0	11.0	G 3/8"	G 3/8"	2.300
GT-36-S	100.0	73.0	160.0	130.0	20.0	11.0	G 3/8"	G 3/8"	2.530
GT-40	120.0	83.0	194.0	152.0	24.0	17.0	G 3/8"	G 3/8"	3.690
GT-48	120.0	83.0	194.0	152.0	24.0	17.0	G 3/8"	G 3/8"	3.890
GT-48-S	120.0	83.0	194.0	152.0	24.0	17.0	G 3/8"	G 3/8"	4.290



URBAR
ingenieros s.a.

Ctra. Villabona-Asteasu, km 3
Apartado 247
Tel. (+34) 943 691 500
Fax (+34) 943 692 667
E-20159 **Asteasu**

www.urbar.com
E-mail: urbar@urbar.com

Vibradores neumáticos de turbina. Serie GT.

Technical characteristics

Type	Frequency rpm			Force N			Air consumption l / min			Noise level dBA
	2 bar	4 bar	6 bar	2 bar	4 bar	6 bar	2 bar	4 bar	6 bar	
GT-4	14000	15000	15000	135	180	200	33	58	83	60-70
GT-6	11500	12000	12500	130	175	210	33	58	83	60-70
GT-8	36000	42000	46000	990	2060	2910	46	80	112	60-70
GT-10	27500	35000	37500	840	1390	2400	46	80	112	60-70
GT-10-S	17000	23000	25000	650	1350	1950	46	80	112	60-70
GT-13	26000	30000	33000	1400	2440	3730	120	200	290	60-70
GT-16	17000	21500	24000	1220	2090	3160	120	200	290	60-70
GT-16-S	11500	15500	17000	1100	1900	2700	120	200	290	60-70
GT-20	17000	20000	23000	2170	4040	5520	185	325	455	60-70
GT-25	12000	15500	17000	2120	3510	5070	185	325	455	60-70
GT-25-S	8500	11000	13000	2250	3600	4900	185	325	455	60-70
GT-30	13000	14000	16000	3380	5430	7540	330	530	745	60-70
GT-36	8000	10000	13000	3290	5360	7190	330	530	745	60-70
GT-36-S	6100	7200	8300	4100	6200	7500	330	530	745	60-70
GT-40	7700	8800	9500	4300	7300	9800	425	700	970	60-70
GT-48	6000	7500	9700	4900	7700	10500	425	700	970	60-70
GT-48-S	0	5600	6300	0	7500	12000	425	700	970	60-70

Data obtained with a Kistler 3-axis dynamometer on a heavy laboratory test block and displayed by Kistler control monitor (COMO). Frequency and force will decrease on a less rigid mount. Specifications subject to change without notice or obligation.

Description

A high speed range and eccentric working moment are combined in these vibrators to produce a powerful vibration.

The body is made from an extrude stove enamelled aluminium section and the hard coated end plates enables the vibrators to be used in the food and pharmaceutical industries.

The GT-Turbine Vibrators conform to current international noise regulations under factory test conditions.



URBAR
ingenieros s.a.

Ctra. Villabona-Asteasu, km 3
Apartado 247
Tel. (+34) 943 691 500
Fax (+34) 943 692 667
E-20159 **Asteasu**

www.urbar.com
E-mail: urbar@urbar.com