



**URBAR**  
ingenieros s.a.



**Pneumatic  
external vibrator**

**AB-4006**

- For concrete prefab.
- Built in steel.
- High centrifugal force.
- Powerful.
- High frequency.
- With quick fixing device.

# Pneumatic external vibrator. AB-4006.

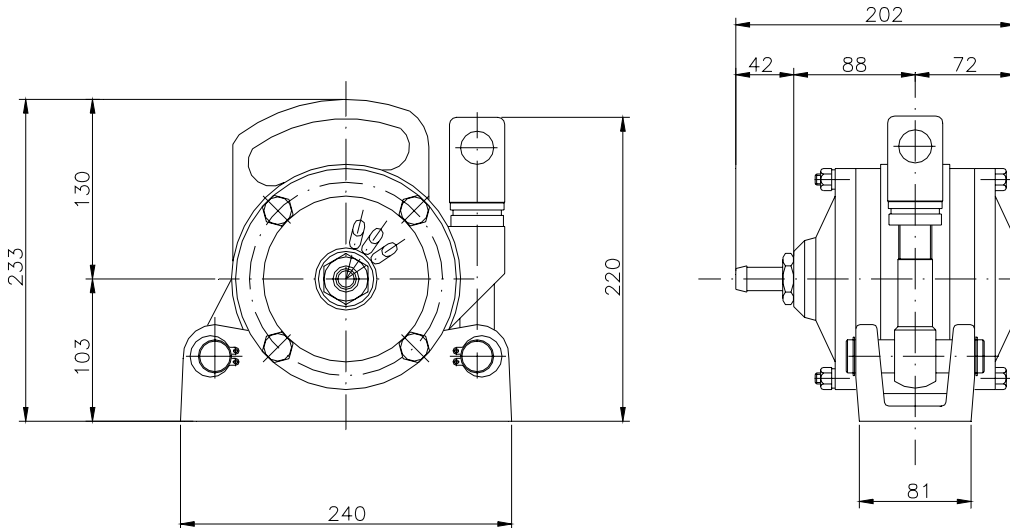

## Technical characteristics

Type	Frequency r.min <sup>-1</sup>	Centrifugal force kN	Consumption l / min	Weight kg
<b>AB-4006</b>	9000	<b>23,1</b>	1830	18

Technical data established with a 6 kg/cm<sup>2</sup> air pressure.

## Description

The AB-4006 vibrator has a body made of cast steel to be fixed mandatory in the quick fixing device.

The device has to be welded in the structure to be vibrated, allowing an easy installation of the vibrator.

The vibrator has a turbine with no bearings. There are only three moving parts: the inner rotor, the external rotor and the blade.

The AB-4006 vibrator is used in vibrating tables, for small pieces or in moulds for big prefab concrete pieces.



The AB-4006 noise level may reach, in normal functioning, up to 110 dbA.



**URBAR**  
ingenieros s.a.

Ctra. Villabona-Asteasu, km 3  
Apartado 247  
Tel. (+34) 943 691 500  
Fax (+34) 943 692 667  
E-20159 **Asteasu**

www.urbar.com  
E-mail: urbar@urbar.com